

## 7/8/955

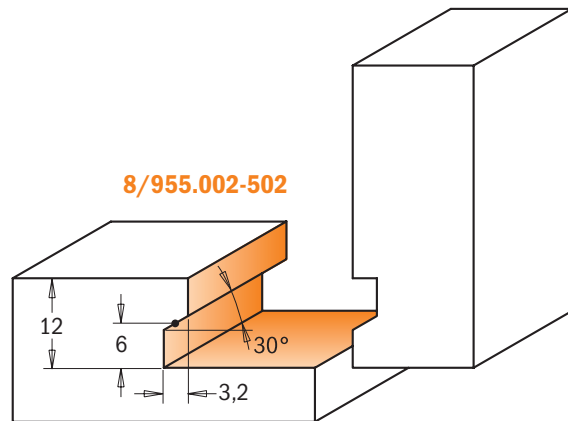

Con queste frese CMT otterrete in maniera rapida ed accurata incastri per cassette solidi e robusti. Attenetevi all'esempio riportato per produrre i vostri cassettei.

**ATTENZIONE:** utilizzate queste frese esclusivamente con elettrofresatrici o pantografi fissati ad un banco munito di guida.

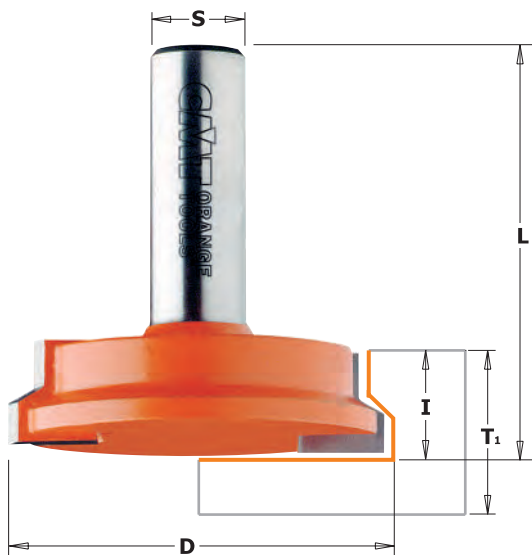

Profili in scala 1:1

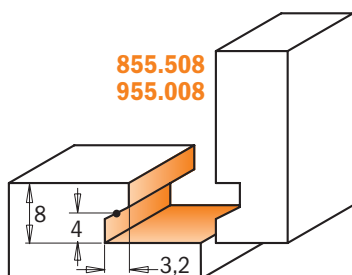

Profili in scala 1:1

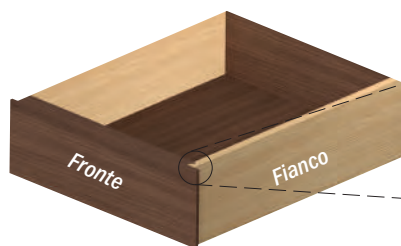
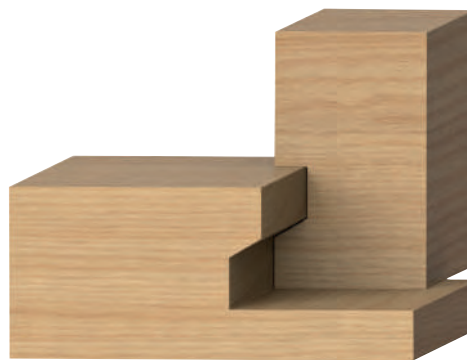

Parte sporgente per battuta cassetto

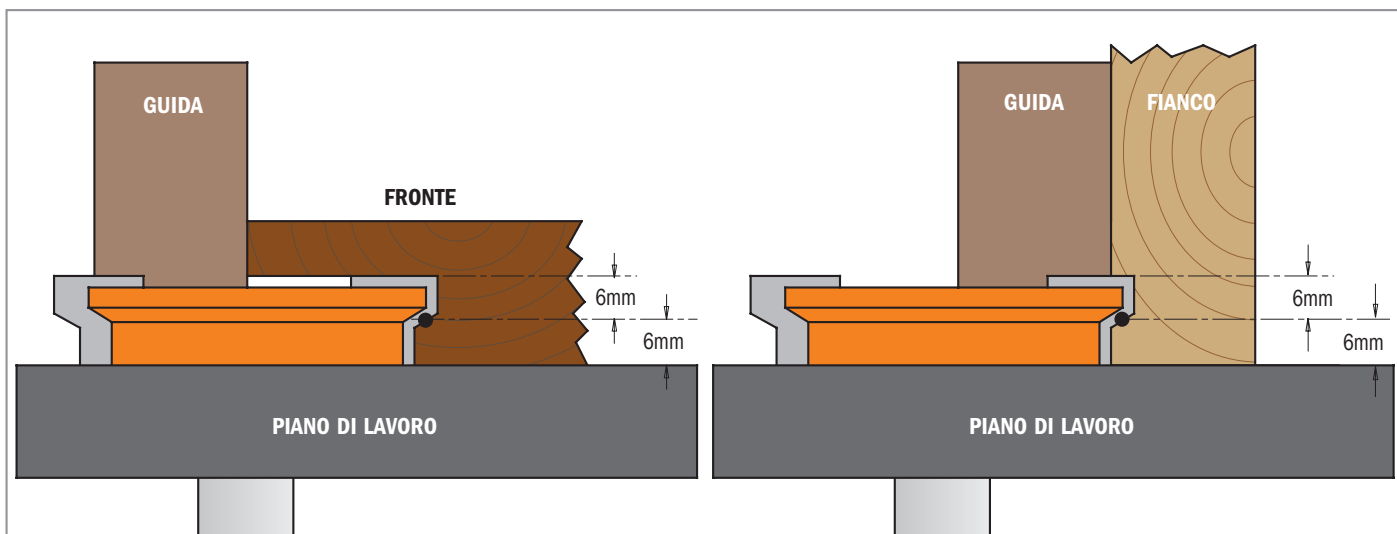

D mm	T <sub>1</sub>		I mm	L mm	Box	CODICE S=Ø6mm	CODICE S=Ø6,35mm	CODICE S=Ø8mm	CODICE S=Ø12mm	CODICE S=Ø12,7mm
	min. mm	max. mm								
25,4	9,5	15,87	12,7	54	10			955.008.11		855.508.11
31,7	15,87	25,4	12,7	44,5	10	755.002.11	855.002.11	955.002.11		
50,8	15,87	25,4	12,7	50,8	10				955.502.11	855.502.11